

## Calibration Procedures

Agilent Technologies Calibration Services	2
Calibration Interval	2
Time Required for Calibration	3
Automating Calibration Procedures	3
Recommended Test Equipment	4
Calibration Security	5
Calibration Message	6
Calibration Count	6
Calibration Process	7
Aborting a Calibration in Progress	7
Performance Verification Tests	8
Internal DMM	10
34951A 4-Ch Isolated DAC Module	26
34952A Multifunction Module	31
Relay Plug-in Modules	33
Thermocouple Reference Junction 34921A (Optional)	35



## Calibration Procedures

This manual contains procedures for verification of the instrument's performance and adjustment (calibration).

**Closed-Case Electronic Calibration** The instrument features closed-case electronic calibration. No internal mechanical adjustments are required. The instrument calculates correction factors based upon the input reference value you set. The new correction factors are stored in non-volatile memory until the next calibration adjustment is performed. Non-volatile EEPROM calibration memory does not change when power has been off or after a remote interface reset.

### Agilent Technologies Calibration Services

When your instrument is due for calibration, contact your local Agilent Service Center for a low-cost recalibration. The 34980A is supported on automated calibration systems which allow Agilent to provide this service at competitive prices.

### Calibration Interval

The instrument should be calibrated on a regular interval determined by the measurement accuracy requirements of your application.

A 1-year interval is adequate for most applications. Accuracy specifications are warranted only if adjustment is made at regular calibration intervals. Accuracy specifications are not warranted beyond the 1-year calibration interval. Agilent does not recommend extending calibration intervals beyond 2 years for any application.

### Adjustment is Recommended

Specifications are only guaranteed within the period stated from the last adjustment. Whatever calibration interval you select, Agilent recommends that complete re-adjustment should always be performed at the calibration interval. This will assure that the 34980A will remain within specification for the next calibration interval. This criteria for re-adjustment provides the best long-term stability.

Performance data measured during Performance Verification Tests does not guarantee the instrument will remain within these limits unless the adjustments are performed.

Use the Calibration Count feature (see [page 6](#)) to verify that all adjustments have been performed.

### Time Required for Calibration

The 34980A can be automatically calibrated under computer control. With computer control you can perform the complete calibration procedure and performance verification tests in less than 30 minutes once the instrument is warmed-up (see Test Considerations on [page 11](#)).

### Automating Calibration Procedures

You can automate the complete verification and adjustment procedures outlined in this manual. You can program the instrument configurations specified for each test over the remote interface. You can then enter readback verification data into a test program and compare the results to the appropriate test limit values.

You must adjust the instrument using the remote interface. Adjustment cannot be performed from the local front-panel. The instrument must be unsecured prior to initiating the calibration procedure (see “[Calibration Security](#)” on [page 5](#)).

For further information on programming the instrument, see see chapter 2 in the *34980A User's Guide*.

## Recommended Test Equipment

The test equipment recommended for the performance verification and adjustment procedures is listed below. If the exact instrument is not available, substitute calibration standards of equivalent accuracy.

A suggested alternate method would be to use the Agilent 3458A 8½-digit Digital Multimeter to measure less accurate yet stable sources. The output value measured from the source can be entered into the instrument as the target calibration value.

Application	Recommended Equipment	Accuracy Requirements
Zero Calibration	None	4 -terminal all copper short
DC Voltage	Fluke 5700A	<1/5 instrument 24 hour spec
DC Current	Fluke 5700A/ 5725A	<1/5 instrument 24 hour spec
Resistance	Fluke 5700A	<1/5 instrument 24 hour spec
AC Voltage	Fluke 5700A/ 5725A	<1/5 instrument 24 hour spec
AC Current	Fluke 5700A/ 5725A	<1/5 instrument 24 hour spec
Frequency	Agilent 33220A	<1/5 instrument 24 hour spec
Analog Output 34951A	Internal DMM	<1/5 instrument 24 hour spec
Analog Output 34952A	Internal DMM	<1/5 instrument 24 hour spec
Thermocouple Reference Junction 34921A with 34921T Only	J Type Calibrated Thermocouple Triple Point Cell	$\pm 0.1 \times ^\circ\text{C}$
Relay contact resistance <sup>[1]</sup> All switch modules	Internal DMM	$\pm 0.001\Omega$ resolution

[1] Optional test if not using relay cycle count.

## Calibration Security

This feature allows you to enter a security code to prevent accidental or unauthorized adjustments of the instrument. When you first receive your instrument, it is secured. Before you can adjust the instrument, you must unsecure it by entering the correct security code.

### NOTE

If you forget your security code, you can disable the security feature by following the procedure below.

- The security code is set to AT34980 when the instrument is shipped from the factory. The security code is stored in non-volatile memory, and does not change when power has been off, after a Factory Reset (\*RST command), or after an Instrument Preset (SYSTEM:PRESet command).
- The security code may contain up to 12 alphanumeric characters. The first character must be a letter, but the remaining characters can be letters, numbers, or an underscore ( \_ ). You do not have to use all 12 characters but the first character must always be a letter.
- The 34951A 4 Channel DAC has two modes of adjustment, based upon the setting of the calibration security feature. Additional details are described in [“34951A 4-Ch Isolated DAC Module”](#) on page 26.

Use the CALibration:SECure:STATE <mode>, <code> command to secure or unsecure the instrument. Refer to the *34980A Programmer's Reference Help File* for complete information.

**To Unsecure the Instrument Without the Security Code** To unsecure the instrument without the correct security code, follow the steps below.

- 1 Turn off the instrument.
- 2 Press and hold the DMM (Measure) key and CANCEL key and turn on the unit. You can release the keys when the unit has completed the power on sequence.
- 3 Send the CALibration:SECure:STATE OFF, <code> command to the instrument. You may use any valid sequence of characters for the <code> value.
- 4 The unit is now unsecured for calibration.
- 5 Enter a new security code when calibration is complete. Be sure to remember the new security code.

## Calibration Message

The instrument allows you to store a message in calibration memory. You may store a calibration message for the mainframe, the DMM, the 34951A 4-Ch Isolated DAC Module, and 34952A Multifunction Module. For example, you can store such information as the date when the last calibration was performed, the date when the next calibration is due, the instrument's serial number, or even the name and phone number of the person to contact for a new calibration.

- You can record a calibration message only from the remote interface and only when the instrument is unsecured. You can read the calibration message whether the instrument is secured or unsecured.
- The calibration message may contain up to 40 characters.
- Remote Interface Commands:

```
CALibration:STRing <string>,{<slot>|MAINframe|DMM}
CALibration:STRing? {<slot>|MAINframe|DMM}
```

## Calibration Count

You can query the mainframe, the DMM, the 34951A 4-Ch Isolated DAC Module, and 34952A Multifunction Module to determine how many calibrations have been performed. Note that your instrument was calibrated before it left the factory. When you receive your instrument, be sure to read the count to determine its initial value.

- The calibration count increments up to a maximum of  $2^{32}$  after which it rolls over to "0". Since the value increments by one for each calibration point, a complete calibration may increase the value by many counts.
- The calibration count is also incremented with calibrations of the 34951A 4-Ch DAC and DAC channels on the 34952A multifunction module.
- Remote Interface Command:

```
CALibration:COUNT? {<slot>|MAINframe|DMM}
```

## Calibration Process

The following general procedure is the recommended method to complete a full instrument calibration.

- 1 Read “[DMM Test Considerations](#)” on page 11 and “[Plug-in Module Test Considerations](#)” on page 25.
- 2 Perform the verification tests to characterize the instrument (incoming data).
- 3 Unsecure the instrument for calibration (“[Calibration Security](#)” on page 5).
- 4 Perform the DMM adjustment procedures (“[Internal DMM Adjustments](#)” on page 20).
- 5 Perform the DAC adjustment procedures if either the 34951A (“[34951A 4-Ch Isolated DAC Module](#)” on page 26) or 34952A (“[34952A Multifunction Module](#)” on page 31) is installed.
- 6 Secure the instrument against calibration.
- 7 Note the new security code and calibration count in the instrument’s maintenance records.

### NOTE

The 34951A 4-Ch Isolated DAC is intended to be adjusted frequently to compensate for changes in the module’s environment. These adjustments can be made either volatile or non-volatile. See [page 26](#) for details.

## Aborting a Calibration in Progress

Sometimes it may be necessary to abort a calibration after the procedure has already been initiated. You can abort a calibration at any time on any module by turning off the power. You can abort a calibration on the internal DMM or the 34951A 4-Ch Isolated DAC by issuing a remote interface device clear message. You can abort a calibration on the 34952A Multifunction Module by sending the `CALibration:ABORT` command.

### CAUTION

If you abort a calibration in progress when the instrument is attempting to write new calibration constants to EEPROM, you may lose all calibration constants for the function. Typically, upon re-applying power, the instrument will report error **705 Cal:Aborted**. You may also generate errors 740 through 746. If this occurs, you should not use the instrument until a complete re-adjustment has been performed.

## Performance Verification Tests

Use the Performance verification Tests to verify the measurement performance of the instrument. The performance verification tests use the instrument's specifications listed in the *34980A's Product Data Sheet*.

You can perform four different levels of performance verification tests:

- **Self-Test** A series of internal verification tests that give a high confidence that the instrument is operational.
- **Quick Verification** A combination of the internal self-tests and selected verification tests.
- **Performance Verification Tests** An extensive set of tests that are recommended as an acceptance test when you first receive the instrument or after performing adjustments.
- **Optional Verification Tests** Tests not performed with every calibration. Perform these tests to verify additional specifications or functions of the instrument.

### Self-Test

A brief power-on self-test occurs automatically whenever you turn on the instrument. This limited test assures that the instrument is capable of operation and also checks the plug-in modules for basic operation.

- During the self-test all display segments and annunciators are lit.
- If the self-test fails, the ERROR annunciator turns on. Read any errors using the front panel View menu, or use the `SYSTEM:ERROR?` command query from the remote interface. If repair is required, contact an Agilent Service Center.
- If all tests pass, you have a high confidence (~90%) that the instrument is operational.
- You can initiate a more complete self test by sending the `*TST?` command to the instrument. This command returns a "+0" if all the self-tests pass, or a "+1" if a failure occurred. Depending upon the number and type of modules installed, this command may take up to 2½ minutes to complete. You may need to set an appropriate interface time-out value.



### Quick Performance Check

The quick performance check is a combination of internal self-test and an abbreviated performance test (specified by the letter **Q** in the performance verification tests). This test provides a simple method to achieve high confidence in the instrument's ability to functionally operate and meet specifications. These tests represent the absolute minimum set of performance checks recommended following any service activity. Auditing the instrument's performance for the quick check points (designated by a **Q**) verifies performance for "normal" accuracy drift mechanisms. This test does not check for abnormal component failures.

To perform the quick performance check, do the following:

- Perform a self-test as described on [page 8](#).
- Perform only the performance verification tests indicated with the letter **Q**.

If the instrument fails the quick performance check, adjustment or repair is required.

### Performance Verification Tests

The performance verification tests are recommended as acceptance tests when you first receive the instrument. The acceptance test results should be compared against the 90 day test limits. You should use the 24-hour test limits only for verification within 24 hours after performing the adjustment procedure. After acceptance, you should repeat the performance verification tests at every calibration interval.

If the instrument fails performance verification, adjustment or repair is required.

Adjustment is recommended at every calibration interval. If adjustment is not made, you must guard band, using no more than 80% of the specifications, as the verification limits.

# Internal DMM

## Input Connections

Test connections to the internal DMM are best accomplished using the rear panel Analog Bus connector (ABus). You may need to remove the cover for access to this connector. A test fixture can be constructed using a standard DB9 male connector, some shielded twisted pair Teflon insulated cables, and appropriate connectors for the calibrator output you are using.

You may also use one of the multiplexer modules to connect the calibrator output to the DMM. If you use a multiplexer module, you must take into account any additional relay contacts and resistances in the measurement path. In this manual, the direct ABus connection is the one described.

Connections for the ABus connector are shown below.

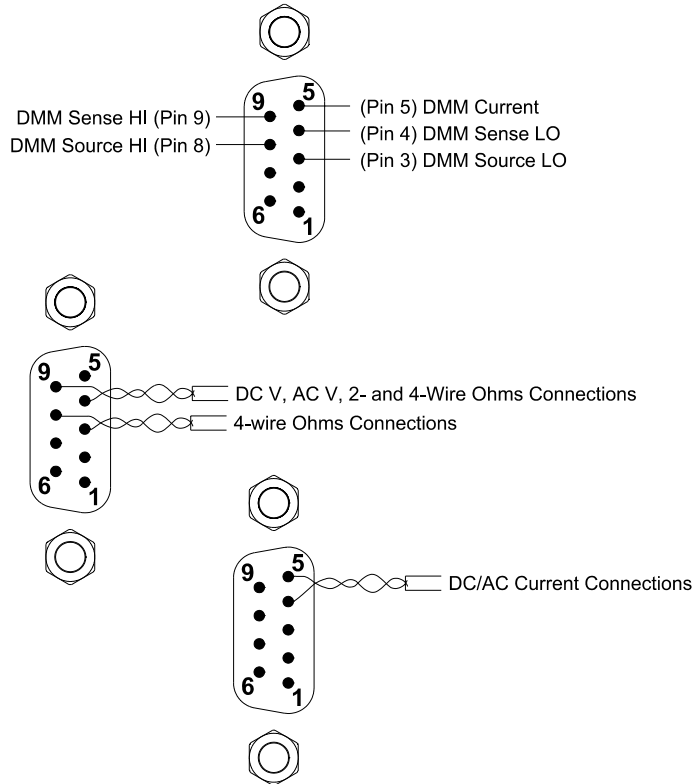

**NOTE**

Use shielded twisted pair Teflon<sup>®</sup> insulated cables to reduce settling and noise errors. Connect the shield to the source LO output.

Teflon<sup>®</sup> is a registered trademark of E.I. du Pont de Nemours and Company.

## DMM Test Considerations

Errors may be induced by ac signals present on the input leads during a self-test. Long test leads can also act as an antenna causing pick-up of ac signals.

For optimum performance, all procedures should comply with the following recommendations:

- Assure that the calibration ambient temperature is stable and between 18 °C and 28 °C. Ideally the calibration should be performed at 23 °C ±1 °C.
- Assure ambient relative humidity is less than 80%.
- Allow a 1.5-hour warm-up period with a copper short connected. The connections are shown in the figure on [page 10](#).
- Use shielded twisted pair Teflon® insulated cables to reduce settling and noise errors. Keep the input cables as short as possible.
- Connect the input cable shield to the source LO output. Except where noted in the procedures, connect the calibrator LO source to earth ground.
- Either remove all modules from the mainframe, or reset the modules to ensure no module is connected to the backplane ABus.

Because the instrument is capable of making highly accurate measurements, you must take special care to ensure that the calibration standards and test procedures used do not introduce additional errors. Ideally, the standards used to verify and adjust the instrument should be an order of magnitude more accurate than each instrument range full scale error specification.

For the dc voltage, dc current, and resistance gain verification measurements, you should take care to ensure the calibrator's "0" output is correct. If necessary, the measurements can be referenced to the calibrator's "0" output using  $Mx + B$  scaling (see Chapter 2 in the User's Guide). You will need to set the offset for each range of the measuring function being verified.

## Internal DMM Verification Tests

### Zero Offset Verification

This procedure is used to check the zero offset performance of the internal DMM. Verification checks are only performed for those functions and ranges with unique offset calibration constants. Measurements are checked for each function and range as described in the procedure on the next page.

### Zero Offset Verification Procedure

- 1 Make sure you have read “DMM Test Considerations” on page 11.
- 2 Short all the inputs on the input test connector (see page 10). Leave the Current input open. Connect the shorts as close to the input connector as possible.
- 3 Select each function and range in the order shown in the table below. Make a measurement and return the result. Compare measurement results to the appropriate test limits shown in the table.

Input	Function <sup>[1]</sup>	Range	Quick Check	Error from Nominal		
				24 hour	90 day	1 year
Open	DC Current	10 mA		± 1 µA	± 2 µA	± 2 µA
Open		100 mA	<b>Q</b>	± 4 µA	± 5 µA	± 5 µA
Open		1 A		± 60 µA	± 100 µA	± 100 µA
Short	DC Volts	100 mV		± 3.5 µV	± 4 µV	± 4 µV
Short		1 V		± 6 µV	± 7 µV	± 7 µV
Short		10 V	<b>Q</b>	± 40 µV	± 50 µV	± 50 µV
Short		100 V		± 600 µV	± 600 µV	± 600 µV
Short		300 V		± 6 mV	± 9 mV	± 9 mV
Short	2-Wire Ohms <sup>[2]</sup> and 4-Wire Ohms	100 Ω		± 3.5 mΩ	± 4 mΩ	± 4 mΩ
Short		1 kΩ		± 6 mΩ	± 10 mΩ	± 10 mΩ
Short		10 kΩ	<b>Q</b>	± 50 mΩ	± 100 mΩ	± 100 mΩ
Short		100 kΩ		± 500 mΩ	± 1 Ω	± 1 Ω
Short		1 MΩ		± 10 Ω	± 10 Ω	± 10 Ω
Short		10 MΩ		± 100 Ω	± 100 Ω	± 100 Ω
Short		100 MΩ		± 10 kΩ	± 10 kΩ	± 10 kΩ

[1] Select 6½ digit resolution.

[2] For 2-wire ohms using a multiplexer for the input connections, an additional 4 Ω of error for the relay contacts must be added.

**Q:** Quick performance verification test points.

#### NOTE

Zero offset calibration using a multifunction calibrator is NOT recommended. The calibrator and cabling offset can be large and unstable causing poor offset calibration of the internal DMM.

### **Gain Verification**

This procedure is used to check the “full scale” reading accuracy of the internal DMM. Verification checks are performed only for those functions and ranges with unique gain calibration constants.

**DC VOLTS, Resistance, and DC CURRENT Gain Verification Test**

- 1 Make sure you have read “[DMM Test Considerations](#)” on page 11.
- 2 Select each function and range in the order shown below. Provide the input shown in the table below.
- 3 Make a measurement and return the result. Compare measurement results to the appropriate test limits shown in the table. (Be certain to allow for appropriate source settling when using the Fluke 5700A.)

Input	Function <sup>[1]</sup>	Range	Quick Check	Error from Nominal		
				24 hour	90 day	1 year
100 mV	DC Volts	100 mV		± 6.5 µV	± 8 µV	± 9 µV
1 V		1 V		± 26 µV	± 37 µV	± 47 µV
10 V		10 V	<b>Q</b>	± 190 µV	± 250 µV	± 400 µV
100 V		100 V	<b>Q</b>	± 2.6 mV	± 4.1 mV	± 5.1 mV
300 V		300 V		± 12 mV	± 19.5 mV	± 22.5 mV
100 Ω		2-Wire Ohms <sup>[2]</sup> and 4-Wire Ohms	100 Ω		± 6.5 mΩ	± 12 mΩ
1 kΩ	1 kΩ		<b>Q</b>	± 26 mΩ	± 90 mΩ	± 110 mΩ
10 kΩ	10 kΩ			± 250 mΩ	± 900 mΩ	± 1.1 Ω
100 kΩ	100 kΩ			± 2.5 Ω	± 9 Ω	± 11 Ω
1 MΩ	1 MΩ			± 30 Ω	± 90 Ω	± 110 Ω
10 MΩ	10 MΩ		<b>Q</b>	± 1.6 kΩ	± 2.1 kΩ	± 4.1 kΩ
100 MΩ <sup>[3]</sup>	100 MΩ			± 310 kΩ	± 801 kΩ	± 810 kΩ
10 mA	DC Current		10 mA		± 1.5 µA	± 5 µA
100 mA		100 mA	<b>Q</b>	± 14 µA	± 35 µA	± 55 µA
1 A		1 A		± 560 µA	± 900 µA	± 1.1 mA

[1] Select 6 ½ digit resolution.

[2] The 2-wire ohms resistance verification test is optional (see “[Gain Adjustment Considerations](#)” on page 21). For 2-wire ohms using a multiplexer for the input connections, an additional 4 Ω of error for the relay contacts must be added. Add a 1-second channel delay when using Fluke 5700 in 2-wire compensated mode. This avoids response time issues with 2-wire compensation when 34980A’s current source contains a pulse.

[3] Verify only, no adjustment required.

**Q:** Quick performance verification test points.

### AC VOLTS Gain Verification Test

Configuration: AC Volts  
 CONFigure[:VOLTage]:AC  
 LF 3 HZ:SLOW  
 [SENSE:]VOLTage:AC:BANDwidth 3

- 1 Make sure you have read “DMM Test Considerations” on page 11.
- 2 Set the AC VOLTS function and the 3 Hz input filter. With the slow filter selected, each measurement takes 7 seconds to complete.
- 3 Select each range in the order shown below. Provide the indicated input voltage and frequency. Compare measurement results to the appropriate test limits shown in the table. (Be certain to allow for appropriate source settling.)

Input			Quick Check	Error from Nominal		
Vrms	Frequency	Range		24 hour	90 day	1 year
100 mV	1 kHz	100 mV		± 70 µV	± 90 µV	± 100 µV
100 mV	50 kHz		<b>Q</b>	± 150 µV	± 160 µV	± 170 µV
1 V	1 kHz	1		± 700 µV	± 900 µV	± 1 mV
1 V	50 kHz			± 1.5 mV	± 1.6 mV	± 1.7 mV
10 V	1 kHz	10 V		± 7 mV	± 9 mV	± 10 mV
10 V	50 kHz		<b>Q</b>	± 15 mV	± 16 mV	± 17 mV
10 V	10 Hz			± 7 mV	± 9 mV	± 10 mV
10 mV <sup>[1]</sup>	1 kHz	100 mV		± 34 µV	± 45 µV	± 46 µV
100 V	1 kHz	100 V	<b>Q</b>	± 70 mV	± 90 mV	± 100 mV
100 V	50 kHz			± 150 mV	± 160 mV	± 170 mV
300 V	1 kHz	300 V		± 270 mV	± 390 mV	± 420 mV
300 V <sup>[2]</sup>	50 kHz			± 600 mV	± 690 mV	± 720 mV

[1] For this test, isolate the calibrator’s output from earth ground to prevent ground noise affecting the reading.

[2] Some calibrators may have difficulty driving the internal DMM and cable load at this V-Hz output. Use short, low capacitance cable to reduce calibration loading. Verification can be performed at >195 Vrms. New test limits can be computed from the accuracy specification shown in the data sheet for the actual test conditions used.

**Q:** Quick performance verification test points.



**NOTE**

The 50 kHz ac voltage test points may fail performance verification if the DMM internal shields have been removed and reinstalled. See “[Gain Adjustment](#)” on page 21 for further information on how to recalibrate the ac voltage function.

**AC CURRENT Gain Verification Test**

Configuration: AC Current  
 CONFigure:CURRent:AC  
 LF 3 HZ:SLOW  
 [SENSE:]CURRent:AC:BANDwidth 3

- 1 Make sure you have read “[DMM Test Considerations](#)” on page 11.
- 2 Set the AC CURRENT function and the 3 Hz input filter. With the slow filter selected, each measurement takes 7 seconds to complete.
- 3 Select each range in the order shown below. Provide the input current and frequency indicated. Compare measurement results to the appropriate test limits shown in the table. (Be certain to allow for appropriate source settling.)

Input			Quick Check	Error from Nominal		
Current	Frequency	Range		24 hour	90 day	1 year
10 mA <sup>[1]</sup>	1 kHz	10 mA		± 14 µA	± 14 µA	± 14 µA
100 mA <sup>[1]</sup>	1 kHz	100 mA	<b>Q</b>	± 600 µA	± 600 µA	± 600 µA
10 mA	1 kHz	1 A		± 1.41 mA	± 1.41 mA	± 1.41 mA
1A <sup>[1]</sup>	1 kHz	1 A		± 1.4 mA	± 1.4 mA	± 1.4 mA

[1] Verify only, no adjustment.

**Q:** Quick performance verification test points.

### Frequency Gain Verification Test

Configuration: Frequency  
 6½ digits  
 [SENSe:]FREQUENCY:APERture 1

- 1 Make sure you have read “DMM Test Considerations” on page 11.
- 2 Select the FREQUENCY function and set 6½ digits.
- 3 Select each range in the order shown below. Provide the input voltage and frequency indicated. Compare measurement results to the appropriate test limits shown in the table. (Be certain to allow for appropriate source settling.)

Input			Quick Check	Error from Nominal		
Voltage	Frequency	Range		24 hour	90 day	1 year
10 mV <sup>[1]</sup>	100 Hz	100 mV		± 0.06 Hz	± 0.1 Hz	± 0.1 Hz
1 V	100 kHz	1 V	<b>Q</b>	± 6 Hz	± 10 Hz	± 10 Hz

[1] Verify only, No adjustment. For this test, isolate the calibrator’s output from earth ground.

**Q:** Quick performance verification test points.

## Optional AC Performance Verification Tests

These tests are *not* intended to be performed with every calibration. They are provided as an aid for verifying additional instrument specifications. There are no adjustments for these tests; they are provided for performance verification only.

Configuration: AC Volts  
 CONFigure[:VOLTage]:AC  
 LF 3 HZ:SLOW  
 [SENSE:]VOLTage:AC:BANDwidth 3

- 1 Make sure you have read “[DMM Test Considerations](#)” on page 11.
- 2 Select the AC Volts function and the 3 Hz filter.
- 3 Select each range in the order shown below. Provide the input voltage and frequency indicated. Compare measurement results to the appropriate test limits shown in the table on the next page. (Be certain to allow for appropriate source settling.)

Input			Error from Nominal		
Voltage	Frequency	Range	24 hour	90 day	1 year
1 V	20 Hz	1 V	± 700 µV	± 900 µV	± 1 mV
1 V	20 kHz	1 V	± 700 µV	± 900 µV	± 1 mV
1 V	100 kHz	1 V	± 6.3 mV	± 6.8 mV	± 6.8 mV
1 V	300 kHz	1 V	± 45 mV	± 45 mV	± 45 mV
10 V	1 kHz	10 V	± 7 mV	± 9 mV	± 10 mV
1 V	1 kHz	10 V	± 3.4 mV	± 4.5 mV	± 4.6 mV
100 mV	1 kHz	10 V	± 13 mV	± 14 mV	± 14 mV

## Internal DMM Adjustments

You will need a test input fixture to adjust the internal DMM (see [page 10](#)).

### Zero Adjustment

Each time you perform a zero adjustment, the Internal DMM stores a new set of offset correction constants for every measurement function and range. The Internal DMM will sequence through all required functions and ranges automatically and store new zero offset calibration constants. All offset corrections are determined automatically. *You may not correct a single range or function without re-entering ALL zero offset correction constants automatically. This feature is intended to save calibration time and improve zero calibration consistency.*

#### NOTE

Never turn off the Internal DMM during Zero Adjustment. This may cause ALL calibration memory to be lost.

### Zero Adjustment Procedure

The zero adjustment procedure takes about 5 minutes to complete. Be sure to allow the instrument to warm up for 2 hours before performing the adjustments.

Follow the steps outlined below. Review “[DMM Test Considerations](#)” on page 11 before beginning this test.

- 1 This procedure will use the copper shorts installed on input test connector. Leave the Current input connection open.
- 2 Set the DC VOLTS function.
- 3 Send the value 0.000000 to the instrument using the `CALibration:VALue 0.000000` command.
- 4 Calibrate the instrument using the `CALibration?` command.
- 5 Perform the “[Zero Offset Verification](#)” on page 12 to check zero calibration results.

## Gain Adjustment

The Internal DMM stores a single new gain correction constant each time this procedure is followed. The gain constant is computed from the calibration value entered for the calibration command and from measurements made automatically during the adjustment procedure.

Most measuring functions and ranges have gain adjustment procedures. Only the 100 M $\Omega$  range does not have gain calibration procedures.

Adjustments for each function should be performed **ONLY** in the order shown in the performance verification table. See “[Performance Verification Tests](#)” on page 8 for the tables used for gain adjustments.

### Gain Adjustment Considerations

- The zero adjustment procedure must have been recently performed prior to beginning any gain adjustment procedures.
- The optional –10 Vdc adjustment should be performed only after servicing the Internal DMM's a-to-d converter.
- When performing a 4-wire ohms gain adjustment, a new gain correction constant is also stored for the corresponding 2-wire ohms measurement range. If desired, the 2-wire gain can be adjusted separately after the 4-wire ohms gain calibration is completed. If the 2-wire Ohms gain is adjusted separately, the 2-wire Ohms function will not meet specifications when offset compensated Ohms is used.
- During the ac voltage gain adjustments, some of the dc voltage gain constants are used. Perform the dc voltage gain calibration before the ac voltage gain calibration.

**NOTE**

Never turn off the instrument during a Gain Adjustment. This may cause calibration memory for the present function to be lost.

### Valid Gain Adjustment Input Values

Gain adjustment can be accomplished using the following input values.

Function	Range	Valid Calibration Input Values
DC VOLTS	100 mV to 100 V	0.9 to 1.1 x Full Scale
	300 V	250 V to 303 V
OHMS, OHMS 4W	100Ω to 10 MΩ	0.9 to 1.1 x Full Scale
DC CURRENT	10 mA to 1 A	0.9 to 1.1 x Full Scale
AC VOLTS [1]	10 mV to 100 V	0.9 to 1.1 x Full Scale
	300 V	95 V to 303 V
AC CURRENT	1 A	9 mA to 11 mA
FREQUENCY	Any	Any Input > 100 mV rms, 1 kHz –100 kHz

[1] Valid frequencies are as follows: 1 kHz ± 10% for the 1 kHz calibration, 45 kHz–100 kHz for the 50 kHz calibration, and 10 Hz ± 10% for the 10 Hz calibration.

### Gain Adjustment Procedure

Adjustment for each function should be performed only in the order shown in the performance verification table. The performance verification tables used for gain adjustments start on [page 14](#).

Review the “[DMM Test Considerations](#)” on page 11 and “[Gain Adjustment Considerations](#)” on page 21 sections before beginning this test.

Configuration: DC functions – 6½ digits  
AC functions – LF 3 HZ:SLOW

- 1 Configure each function and range shown in the gain verification tables (starting on [page 14](#)).
- 2 Apply the input signal shown in the “Input” column of the appropriate verification table.

#### NOTE

Always complete tests in the same order as shown in the appropriate verification table.

- 3 Send the actual input value to the instrument using the `CALibration:VALue <value>` command.
- 4 Calibrate the instrument using the `CALibration?` command.
- 5 Perform the appropriate Gain Verification Test to check the calibration results.
- 6 Repeat steps 1 through 5 for each gain verification test point shown in the tables.

#### NOTE

Each range in the gain adjustment procedure takes less than 20 seconds to complete.

### –10 Vdc Adjustment Procedure (Optional)

The –10 Vdc calibration electronically enhances the Internal DMM’s a-to-d converter linearity characteristic. This adjustment should ONLY be performed after servicing the A-to-D converter or replacement of the calibration RAM.

You will need an input test connector as described in “Input Connections” on page 10.

1 If a zero calibration has not been performed recently, perform one before beginning this procedure (see page 20).

2 Configure the instrument as follows:

DC VOLTS

10 V range [SENSe:]VOLTage[:DC]:RANGE 10

6½ digits

INTEG 100 PLC [SENSe:]VOLTage[:DC]:NPLC 100

INPUT R > 10 G [SENSe:]VOLTage[:DC]:IMP:AUTO ON

3 Measure and note the voltage offset present at the end of the measurement cable by shorting the ends of the cable. Be sure to use a copper wire and allow enough time for the residual thermal offset to stabilize (usually about 1 minute).

4 Connect the input cable to the calibrator output and set the calibrator to output +10V. Allow enough settling time for any thermal offset voltages to stabilize (usually about 1 minute).

5 Perform a +10V dc gain calibration.

6 Send an adjustment to the instrument. The adjustment value is the sum of the calibrator output and the measured offset (from step 3). For example, if the calibrator output is 10.001 volts and the measured offset is 10 µV, send the value +10.001010 volts. When the adjustment finishes, verify that new readings fall within ±20 µV of the calibrator output plus the offset.

7 Reverse the cable connections to the calibrator to create a -10 Vdc voltage standard. You must physically reverse the cables. *DO NOT switch the output polarity of the calibrator.*

8 Perform a -10V DC gain calibration. Be sure to allow time for thermal offsets to stabilize (usually about 1 minute).

9 Send an adjustment to the instrument. The adjustment value is the sum of the calibrator output and the measured offset (from step 3). Using the previous example values, enter 10 µV minus 10.001 volts or -10.000990 volts.

10 When the adjustment finishes, verify that new readings fall within ± 30 µV of the calibrator output minus the offset.



## Plug-in Modules

### Plug-in Module Test Considerations

For optimum performance, all test procedures should comply with the following recommendations:

- Assure that the calibration ambient temperature is stable and between 18 °C and 28 °C. Ideally the calibration should be performed at 23 °C ± 1 °C.
- Assure ambient relative humidity is less than 80%.
- Install the plug-in module and allow a 1 hour warm-up period before verification or adjustment.
- Use shielded twisted pair Teflon® insulated cables to reduce settling and noise errors. Keep the input cables as short as possible.
- Remove all user wiring and connections from the plug-in modules before verification or adjustment.
- Use 4-wire Ohms measurement techniques for checking relay contact resistance. Check directly at the terminals where possible.

## 34951A 4-Ch Isolated DAC Module

Each isolated DAC output channel can be measured and adjusted using the internal DMM. The Internal DMM is recommended because it compensates for ambient temperature.

The 34951A features “auto-calibration”. Upon receipt of the calibration command, all channels on the DAC are adjusted using the internal DMM. Additionally you may adjust **ALL** 34951A modules installed in the instrument with one command. The adjustments require approximately 1 minute per module.

### NOTE

The 34951A 4-Ch Isolated DAC is intended to be adjusted frequently to compensate for changes in the module’s environment (changes in ambient temperature, changing the mainframe slot used, adding or removing modules to a system). These adjustments can be made either volatile or non-volatile as described below. The adjustment procedure is given beginning on [page 30](#).

There are two ways to adjust the DACs, depending upon the state of calibration security (see “[Calibration Security](#)” on [page 5](#)).

- If the instrument is secured for calibration when the adjustment is begun, the adjustments are considered volatile. All adjustments are discarded when power is cycled. This provides an easy means to make immediate temperature-compensated adjustments to the DAC outputs without overwriting stored calibration constants.

When this type of adjustment is made, the calibration count (see [page 6](#)) is not advanced.

- If the instrument is unsecured for calibration, the adjustments are written to non-volatile calibration memory. The calibration count (see [page 6](#)) is advanced.

### 34951A Verification

**Test Connections** The DAC outputs can be measured using an external voltmeter, or using a test fixture such as the one shown below, with the internal DMM via the ABus connector on the instrument's rear panel.

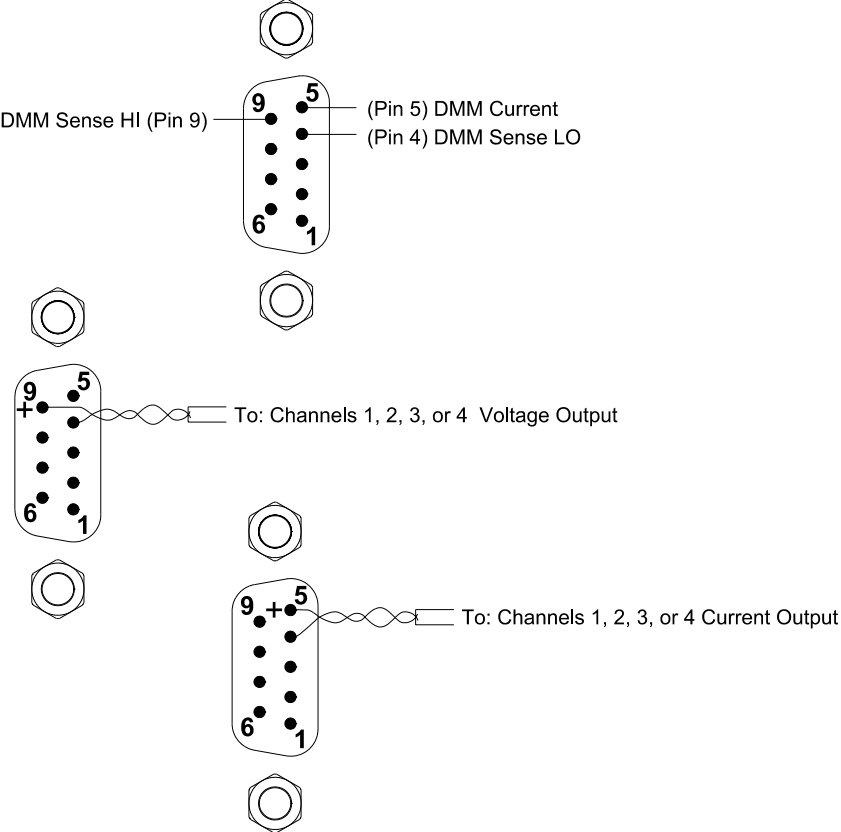

**Analog Output Verification Test** This procedure is used to check the calibration of the analog outputs on the 34951A 4-channel DAC Module. Verification checks are performed only for those output values with unique calibration constants.

- 1 Using the input test connector described on [page 27](#), leave the current input terminal open. Set the DMM to the 100 mA range. Make and record a current measurement. This value will be used as an offset value during the output current zero verification.
- 2 Make voltage measurement connections to channel 1 of the module.
- 3 Set each output voltage value in the table below and make a measurement. Compare measurement results to the appropriate test limits shown in the table.

**NOTE**

It is not necessary to test the voltage output at the full rated 10 mA load. If you test the output using a load, connect the sense terminals.

- 
- 4 Make current measurement connections to channel 1 of the module. Set the DMM to the 100 mA range.
  - 5 Set each output current value in the table below and make a measurement. Compare measurement results to the appropriate test limits shown in the table. When measuring the 0 mA output value, apply the offset value from step 1 to the measured value.
  - 6 Repeat steps 2 through 5 for channels 2, 3 and 4.
  - 7 Remove the input test connector.

<b>Output Voltage</b>	<b>Quick Check</b>	<b>Error from Nominal (90 day)</b>
16 V	<b>Q</b>	± 11 mV
12 V		± 9 mV
10 V		± 8 mV
8 V		± 7 mV
4 V		± 5 mV
0 V	<b>Q</b>	± 3 mV
-4V		± 5 mV
-8 V		± 7 mV
-10 V		± 8 mV
-12 V		± 9 mV
-16 V	<b>Q</b>	± 11 mV
<b>Output Current</b>	<b>Quick Check</b>	<b>Error from Nominal (90 day)</b>
20 ma	<b>Q</b>	± 23 $\mu$ A
15 mA		± 18.5 $\mu$ A
10 mA		± 14 $\mu$ A
5 ma		± 9.5 $\mu$ A
0 mA <sup>[1]</sup>	<b>Q</b>	± 5 $\mu$ A
-5 mA		± 9.5 $\mu$ A
-10 ma		± 14 $\mu$ A
-15 mA		± 18.5 $\mu$ A
-20 mA	<b>Q</b>	± 23 $\mu$ A

[1] Apply a measured "0" offset to this measurement.

### Analog Output Adjustment

Install the 34951A module in the mainframe and allow a 1 hour warm-up before performing these procedures.

This adjustment procedure sets a zero adjustment and a gain adjustment constant for each DAC output. You must perform all the adjustments on one analog output channel before adjusting the other analog output channel.

- 1 Install the module(s) in the instrument. Remove any inputs from the ABus connector.

#### CAUTION

Remove any ABus connector before performing this procedure.

---

- 2 Set the calibration security for the adjustment mode you desire, see [page 26](#).
- 3 Send the `CALibration:MODule? <slot>` command to begin the auto-calibration procedure for all channels on the module in `<slot>`. You may use the `CALibration:MODule? ALL` command to perform the auto-calibration on all channels for all modules installed in the mainframe. The complete procedure may take up to 1 minute per module. Be sure to set the remote command time-out value appropriately.
- 4 The command returns a value of “+0” if the calibration is successful. A returned value of “+1” indicates a calibration failure.

#### NOTE

Following the auto-calibration procedure, the DMM is left in its reset date (DCV).

---

## 34952A Multifunction Module

The only calibration constants are for the two DAC outputs on the 34952A Multifunction Module. These outputs can be measured using an external voltmeter, or with a test fixture such as the one shown below, using the internal DMM via the ABus connector on the instrument's rear panel.

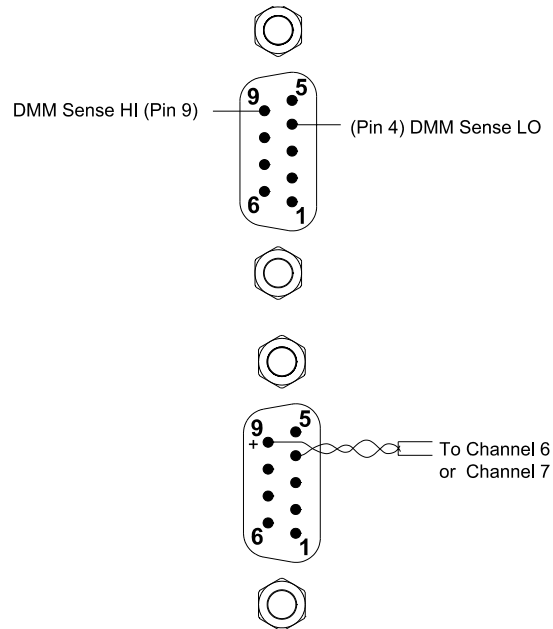

### 34952A Verification

**Analog Output Verification Test** This procedure is used to check the calibration of the analog outputs on the 34952A Multifunction Module. Verification checks are performed only for those output values with unique calibration constants.

- 1 Use the internal DMM to measure the output of each channel. You will need to physically move the input connections on the 34952A module to channel 6 and then channel 7.
- 2 For each analog output (channel 6 and channel 7), set each output value in the table below. Compare measurement results to the appropriate test limits shown in the table.

#### NOTE

It is not necessary to test the voltage output at the full rated 10 mA load.

Output Voltage	Quick Check	Error from Nominal (1 year)
10 V	<b>Q</b>	± 45 mV
0 V	<b>Q</b>	± 20 mV
-10 V		± 45 mV

### Analog Output Adjustment

Install the 34952A module in the mainframe and allow a 1 hour warm-up before performing these procedures.

This adjustment procedure sets a zero adjustment and a gain adjustment constant for each DAC output. You must perform all the adjustments on one analog output channel before adjusting the other analog output channel.

- 1 Install the module(s) in the instrument.
- 2 Unsecure the instrument for calibration (see [page 5](#)).
- 3 Connect channel 6 DAC output to the DMM input. Set the DMM to measure DC volts.
- 4 The calibration procedure makes two adjustments per channel. After sending the first command, measure the module output. Send the measured value to the module and advance to the next point. This procedure is summarized as follows:
  - a Send the following command to begin the procedure.  
CALibration:BEgin:VOLtage 1,@<channel>
  - b Measure the module output.
  - c Send the measured value to the module with the following command:  
CALibration:POINT? <value>
  - d The command returns a “+1” to indicate it is ready for the next point.
  - e Measure the module output.
  - f Send the measured value to the module with the following command:  
CALibration:POINT? <value>
  - g The command returns a “+0” to indicate the calibration on the channel is completed.
- 5 Repeat steps 3 and 4 for channel 7.



## Relay Plug-in Modules

There are two methods you can use to verify relays:

- Read the relay cycle count.
- Measure the relay contact resistance.

### Relay Cycle Count

The instrument has a Relay Maintenance System to help you predict relay end-of-life. The instrument counts the cycles on each relay in the instrument and stores the total count in non-volatile memory on each switch module. You can use this feature on any of the relay modules and the internal DMM.

- In addition to the channel relays, you can also query the count on backplane relays and bank relays. Note that you cannot control the state of these relays from the front panel but you can query the count.
- You can also query the state of the six relays on the internal DMM. These relays open or close when a function or range is changed on a module.
- You can reset the count but the instrument must be unsecured (see “[Calibration Security](#)” on page 5 to unsecure the instrument).
- The 34923A, 34924A, and 34933A modules can be configured for 2-wire (differential) or 1-wire (single ended) measurements. Since two coils are required to drive each channel relay in the 2-wire mode, the module stores the cycle count for each coil and returns the greater of the two. To determine the cycle count for each coil, reconfigure the module for the 1-wire mode (a power cycle is required) and query the count.
- The FET switches on the 34925A FET Multiplexer module have an infinite life when used under normal operating conditions. Therefore, the cycle count is not recorded and this command always returns “0” (will not generate an error). Although the count on the FET switches is not recorded, you can read the actual cycle count on the mechanical Analog Bus relays.

- On the RF Multiplexer modules (34941A, 34942A), the signal path to the COM terminal consists of both a channel relay and a bank relay. For each bank, the module stores the cycle count for each channel relay, the bank relay, and returns the greater of the two. For example, to determine the cycle count on Channel 11, the module recalls the count on Channel 11, the count on the Bank 1 relay, and returns the greater of the two. In addition, the cycle count on the two channels within the same physical relay package, will always be equal. Therefore, the cycle count for Channels 11 and 12 will always be equal.

Use the `DIAGnostic:RELAy:CYCLes? (@<ch_list>)` command to read relay cycle counts on the following modules:

- 34921A through 34925A Multiplexer Modules
- 34931A through 34933A Matrix Modules
- 34937A and 34938A GP Switch Modules
- 34941A and 34942A RF Multiplexer Modules
- 34946A and 34947A Microwave Switch Modules

Use the `DIAGnostic:DMM:CYCLes? {1|2|3|4|5|6}` command to read relay cycle counts for the internal DMM function and range relays.

By maintaining a count you can estimate which relays are nearing the end of their useful life.

### **Relay Contact Resistance Verification (Optional)**

Optionally, you can create a test fixture for each plug-in module and read the relay contact resistance. By installing shorts on all the input channels on a multiplexer, for example, you can use the internal DMM to measure the 4-wire Ohms values of each channel. Such a measurement would include the relay contact resistance of the channel HI relay contacts, the Channel LO relay contacts and the backplane connection relay contacts.

## Thermocouple Reference Junction 34921A (Optional)

### NOTE

You should perform these verification if you are using the module for thermocouple measurements.

To make a thermocouple measurement a known reference junction temperature measurement must be made. The reference junction temperature is measured by two solid state temperature sensors in the input connection area on the module. The adjustments store calibration constants used to correct the measurements from the temperature sensors.

*Thermocouple measurements using an internal reference are only supported by the 34921A module using the optional 34921T terminal block. The isothermal block is located on, and is an integral part of, the terminal block.*

There are no adjustments for the reference junction.

### Thermocouple Reference Junction Verification

- 1 Read “[Plug-in Module Test Considerations](#)” on page 25.
- 2 Connect a calibrated thermocouple to channel 21.
- 3 Install the module in slot 1.
- 4 Place the J Type calibrated thermocouple at a known temperature (ice bath or calibrator).
- 5 Select Channel 21. Configure the channel as follows:  
 TEMPERATURE  
 THERMOCOUPLE  
 J TYPE  
 INTEG 10 PLC  
 INTERNAL REF

```
SENS:TEMP:TRAN:TYPE TC,(@1021)
SENS:TEMP:TRAN:TC:TYPE J,(@1021)
SENS:TEMP:NPLC 10,(@1021)
SENS:TEMP:TRANS:TC:RJUN:TYPE INT,(@1021)
```

- 6 Subtract the thermocouple error from the measured temperature. Verify the result is within  $\pm 1.0$  °C of the known temperature (set in step 3).